

SmartHK
創新升級 · 香港論壇
Fuzhou · 福州
25 / 5 / 2017



Application Form 參加表格

(For Hong Kong Companies only 只限香港公司參加)

Important ◆ 除註明外，所有資料請以中文填寫 All Information must be completed in Chinese unless otherwise stated. ◆ 「公司名稱」必須與貴公司商業登記証上所列相同，並將作為製作展台名牌之用。 The "Name of Organisation/Company" should be the same as appeared on the Business Registration Certificate and will be used to produce fascia board at your booth. ◆ 下列資料將用於印刷大會場刊 The information listed below will be used in the Fair Catalogue. ◆ 請將申請表寄往以下地址 Mail completed application to: 38/F Office Tower, Convention Plaza, 1 Harbour Road, Wan Chai, HK – Attn: Gloria Ng/ Jeani Wang	Application Deadline 截止報名日期 31/3/2017
	Discount Deadline will be due soon 預先報名優惠 即將截止

PART I 第一部份 Company Information 公司資料

The information supplied in this section will be featured in related marketing materials.

貴公司於此部份所提供之資料將作相關推廣用途。

1. **Company Name:** _____

公司名稱：_____

The "Company Name" should be the same as appeared on the Business Registration Certificate 「公司名稱」應與商業登記証上所列之相同

Company Address in English 英文地址：_____

Company Address in Chinese 中文地址：_____

Tel No. 電話： (852) _____ Fax No. 傳真： (852) _____

E-mail 電子郵件： _____ Website 網址： _____

Business Registration Certificate No. 商業登記証號碼： _____

(Please submit the copy of Business Registration Certificate together with the application form 請將商業登記証副本連同參加表格一起提交)

2. **Delegate** 出席是項活動之公司代表名稱

Name 姓名： Mr./Miss/Ms. _____ (_____ 先生/小姐/女士 (中文))

Position 職位： _____ (_____ (中文))

3. **Information Of Branch Office(s) In The Mainland (if applicable)** 中國內地分公司資料 (如適用)

Name of Branch Office(s) in the Mainland: _____

中國內地分公司名稱： _____

Address of Branch in the Mainland: _____

中國內地分公司地址： _____

Postal Code 郵編： _____

Tel No. 電話： 86-()- _____ Fax No. 傳真： 86-()- _____

E-mail 電子郵件： _____

4. Please choose ONE of the following themed zones for exhibiting, and type of business under the pavilion chosen. Final categorisation and locations are subject to the organiser's final confirmation.

請選擇其中一個主題展區，及相關業務性質。展區及位置分配有待主辦機構最後落實。

Innovative Design and Marketing Zone 設計創新及市場推廣展區

- | | | |
|--|--|---|
| <input type="checkbox"/> Advertising and Marketing
廣告及市場推廣 | <input type="checkbox"/> Architectural Design
建築設計 | <input type="checkbox"/> Design & Branding
設計及品牌策略 |
| <input type="checkbox"/> Digital Entertainment
數碼娛樂 | <input type="checkbox"/> Fashion Design
時裝設計 | <input type="checkbox"/> Industrial and Product Design
工業及產品設計 |
| <input type="checkbox"/> Interior & Spatial Design
室內及空間設計 | <input type="checkbox"/> Licensing
授權 | <input type="checkbox"/> New Media / Apps
新媒體市場推廣 / Apps |
| <input type="checkbox"/> Printing & Packaging Service
印刷及包裝服務 | <input type="checkbox"/> Others, please specify (max. 10 Chinese Words)
其他，請列明 (不多於 10 個中文字): _____ | |

Technological Advancement Zone 科技創新展區

- | | | |
|---|--|---|
| <input type="checkbox"/> 3D Printing Technology
三維打印科技 | <input type="checkbox"/> Environmental Technology
環保科技 | <input type="checkbox"/> Information & Communications
Technology / Retail Technology
信息及通訊技術 / 零售科技 |
| <input type="checkbox"/> New Production Materials / Production
Technology 新開發物料 / 生產技術 | <input type="checkbox"/> Quality Control, Testing
& Certification
質量管理、檢測及認證 | <input type="checkbox"/> Others, please specify (max. 10
Chinese Words) 其他，請列明
(不多於 10 個中文字): _____ |

Management Upgrading Zone 管理創新展區

- | | | |
|---|---|---|
| <input type="checkbox"/> Accounting
會計 | <input type="checkbox"/> Asset Management & Financial
Advisory 資產管理及財務顧問服務 | <input type="checkbox"/> Auditing
審計 |
| <input type="checkbox"/> Business Consultancy
商業諮詢及顧問 | <input type="checkbox"/> Corporate Finance
企業上市、併購及重組 | <input type="checkbox"/> Human Resources Management
人力資源管理 |
| <input type="checkbox"/> Legal Service 法律服務 | <input type="checkbox"/> IP Trading Intermediaries
知識產權貿易中介服務 | <input type="checkbox"/> Logistics / e-commerce
物流 / 電子商貿 |
| <input type="checkbox"/> Patent & IP Protection
專利及商標保護 | <input type="checkbox"/> Outbound Investment
跨境投資 | <input type="checkbox"/> Taxation
稅務 |
| <input type="checkbox"/> Others, please specify (max. 10 Chinese Words) 其他，請列明 (不多於 10 個中文字): _____ | | |

5. **Company Profile & Project Photo 公司簡介及作品照片**

Please submit your company profile in Chinese, company logo and photo of your company's project / design work in a CD-ROM together with the application form 請將 貴公司之中文公司簡介及作品照片燒錄至光碟連同參加表格一起提交

Company Profile in Chinese 中文公司簡介：

Format 格式 : .doc / .txt

No. of Words 字數 : max. 150 words 不多於 150 字

Photos of Project / Design Works 作品照片 (Please provide 1 photo in vertical format. 請提供一張直度照片)：

Format 格式 : .tif / .eps / .psd

Resolution 解析度 : 300 dpi

Size 大小 : As large as possible (min. 10MB for .tif file)

Quantity 數量 : 1 photo

PART II 第二部份 Contact Person Concerning Participation Issues 有關參加事宜之聯絡人

Circulars and related information of the event will be sent to the person below by mail, fax or email

通告及活動有關資料將會以郵遞、傳真或電郵至下列聯絡人

Name 姓名 : Mr./Miss/Ms. (English) _____ 先生/小姐/女士 (中文)

Position 職位 : _____ (English) _____ (中文)

Tel No. 電話 : (852) _____ Fax No. 傳真 : (852) _____

E-mail 電子郵件 : _____

PART III 第三部份**Additional Information 附加資料**

Please provide the following information, which will be used for the organiser's internal reference for arranging networking and business matching activities. 為協助安排交流/商貿配對活動給參展公司，以下資料只供主辦單位作內部參考用。

1. Examples of your Company's Project(s) / Client(s) 貴公司項目/客戶:**2. Main Objective(s) of Participation 參加本活動的主要目的 (Please "✓" the appropriate box. 請在空格內加上✓號)**

- To test market potential 測試市場潛力 To generate sales enquires 收集業務查詢
 To make new contacts 建立新連繫 Other objectives 其他目的 _____

3. Please Specify the Type of Business of your Target Clients 請說明 貴公司目標客戶的業務性質 / 企業類型**PART IV 第四部份****Participation Options 參展方式**

Options 選項	Unit Price 單位費用	15% early-bird Discount 預先報名優惠 即將截止		Quantity 數量
<input type="checkbox"/> Standard Booth 標準攤位 3 sqm 平方米	HK\$5,300	HK\$4,505	X	Unit(s) 個
<input type="checkbox"/> Custom-Built Participation (Carpeted raw space only) 特裝參展 (只有地氈的展覽空地) Minimum 12 sqm 最少租用 12 平方米	HK\$680 per sqm 每平方米	HK\$578 per sqm 每平方米	X	sqm 平方米
額外活動 Additional Offer				
<input type="checkbox"/> Hotel, Flight and Market Visit 兩晚酒店、來回機票及考察活動費用	HK\$3,700 per person 每人	/	X	位
<input type="checkbox"/> Market Visit Only 只參與考察活動	HK\$500 per person 每人	/	X	位

SPECIAL DISCOUNT FOR START-UP 新創企業優惠

Start-up companies who established on **25 May 2014 or after** can enjoy **25% discount** on participation fee. Applicants who wish to enjoy this discount are required to submit Company Registry documents to the Organiser for approval. (This discount cannot be used in conjunction with any other offer) 於 **2014 年 5 月 25 日** 或以後成立的新創企業可享 **75 折** 參展費優惠。新創企業需提交公司註冊證明文件予主辦機構審批方可享用此優惠。(此優惠不可與其他優惠同時使用)

IMPORTANT 請注意：

- Participation fee includes featuring the Participant's company information in the booth and in the event's fair catalogue. 參加費用包括於展位及大會場刊展示公司資料。
- Participating company shall arrange and bear the transportation cost and hotel accommodation, as these are not included in the participation fee. 除上述參加費用外，所有參與活動之公司需自行安排及支付交通及酒店住宿費用。
- Participating company shall also arrange and bear any cost arising from the shipping and transportation of exhibits and/or promotional materials, customs duties, insurance, etc, as these are not included in the participation fee. 除上述參加費用外，參與活動之公司需自行支付展品/宣傳品運輸、關稅、保險等額外費用。

PAYMENT 繳款須知：

- Full payment of participation fee by crossed cheque shall be made payable to "Hong Kong Trade Development Council". 參加費用須以劃線支票全數支付，支票抬頭請註明「香港貿易發展局」。
- When the Application is accepted by the Council, the Applicant will become a Participant. If it subsequently wishes to withdraw its participation, it may be done so by notice in writing to the Council where upon the Participation Fee will be forfeited by the Council. 假若參加者於申請獲接納後撤回申請，不論理由為何，已繳之申請費將不被退回。

REMARKS 附註：

Allocation of booth and all other arrangement in relation to the event's programme will be at the final discretion of the Organiser. 主辦機構保留展位位置之最後分配權，亦保留活動行程安排的最終決定權。

Eligible Hong Kong SMEs exhibiting at SmartHK, Fuzhou may apply for the SME Export Marketing Fund, subject to TID's approval. (www.smefund.tid.gov.hk) 合資格的香港中小企於創新升級，香港論壇參展，可申請工業貿易署「中小企業市場推廣基金」。申請成功與否由工業貿易署決定。(www.smefund.tid.gov.hk)

3 sqm Standard Booth 3 平方米標準攤位

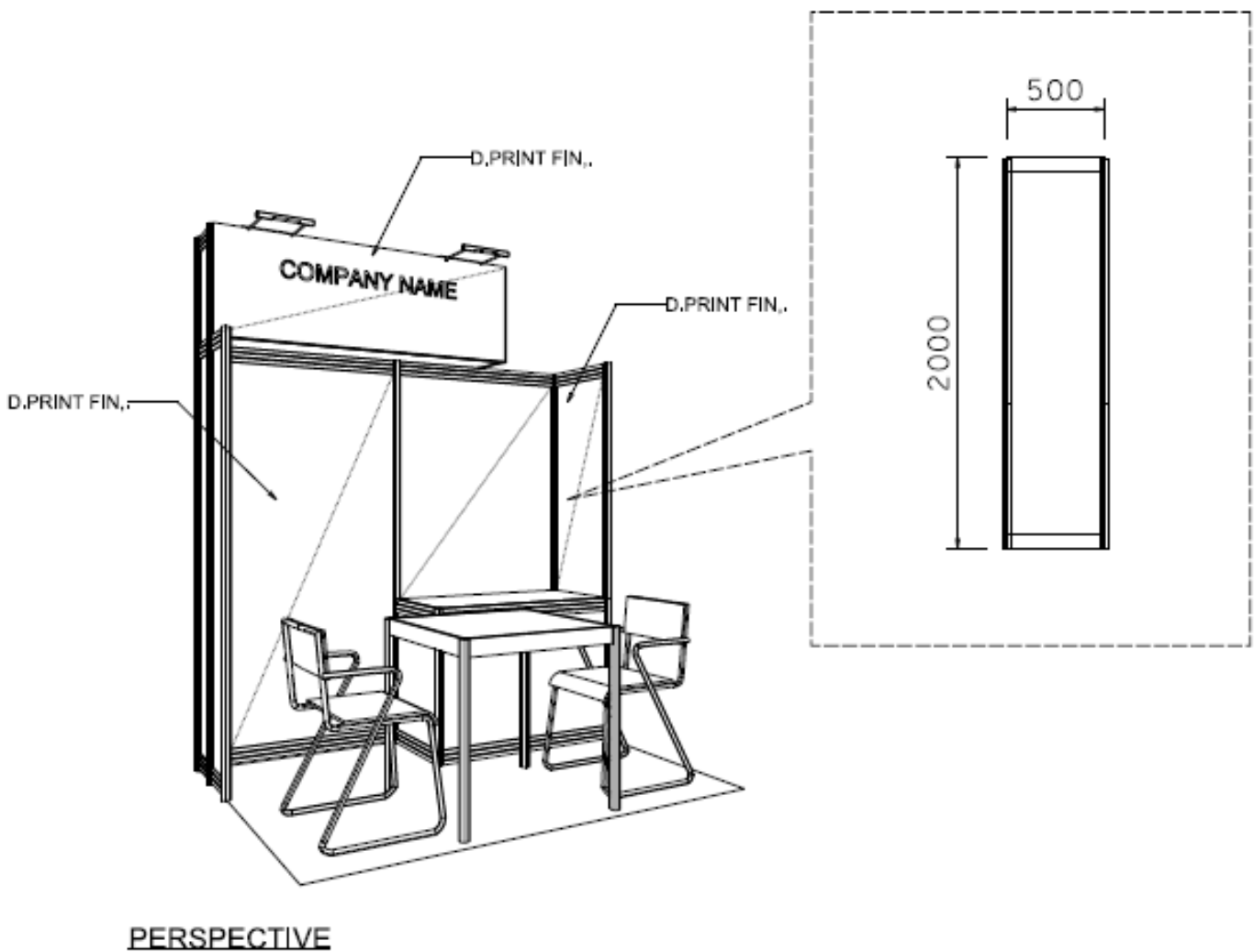
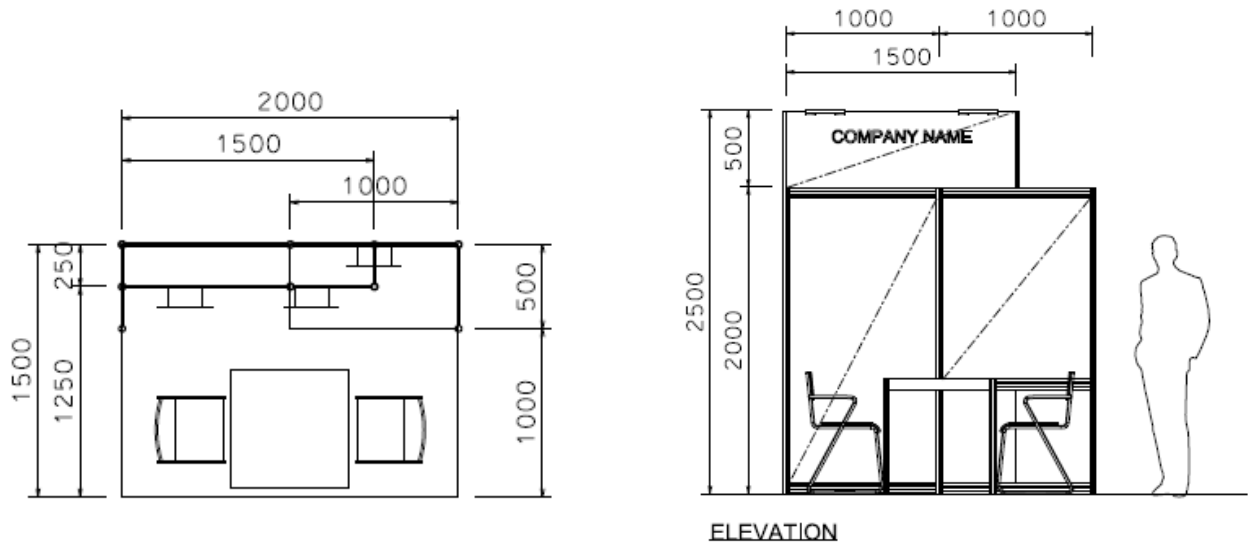

*The organiser reserves the right to keep/amend the specification if necessary and without prior notification.

主辦機構保留更改攤位規格及設施之權利而不另行通知*

PART VI 第六部份 Precaution measures on Accident 安全須知

The following information available in Chinese only.

- 任何在展覽場地進行的工程必須符合香港現行法律及條例，包括但不限於遵從根據香港法例第 282 章僱員補償條例第 40 條購買及持有僱員補償保險單的強制要求，以及主辦機構的規定，參展商與其代理、承建商及分包商均須予以遵守。主辦機構保留權利阻止任何違反上述任何法律及條例的工程進行，參展商不得就任何有關損失或毀壞向主辦機構或其代理提出索償。
- 主辦機構對涉及參展商/參觀者、其個人物品及展品的任何風險，概不負財務或法律責任。參展商應為其展品、攤位裝置、會場及其他第三者投保。此外，參展商必須遵從包括但不限於香港條例第 282 章僱員補償條例(“該條例”)第 40 條的規定，以承擔該參展商在該條例及普通法就他們全部的僱員在工作時受傷而引起的法律責任，不論僱員的合約期或工作時數長短、是全職或兼職、是長工或臨時工。參展商如有貴重展品需要通宵貯存，應自行投保或聘請特別護衛服務，一切費用由參展商負責。參展商如需特別協助，請與主辦機構辦事處聯絡。
- 參展商所聘用的展台承建商必須購買有效之公眾責任保險。每次事故賠償限額不少於港幣 1,000 萬，而保險期內累積賠償額則須無限。保險範圍應包括但不限於人身傷害、財物損毀。此外，承建商必須遵從包括但不限於香港條例第 282 章僱員補償條例(“該條例”)第 40 條的規定，以承擔該承建商在該條例及普通法就他們全部的僱員在工作時受傷而引起的法律責任，不論僱員的合約期或工作時數長短、是全職或兼職、是長工或臨時工。私人承建商必須一直於展覽期間(包括進場及離場)就私人承建商的財物及其活動及其他項目存有生效及充足的保險，包括盜竊、火災、財物損毀、意外、自然災害、天災以及其他通常由承建商投保的及主辦機構要求投保的風險。保險有效期須包括進場、展覽期間及離場〔即 2017 年 5 月 24 至 25 日〕。承建商須於指定日期前將其保險單副本交予主辦機構。
- 參展商必須在任何時候，就盜竊、火災、公眾責任、財產損毀、人身傷害、第三者損失、意外、自然災害、不可抗力以及參展商一般都會投保及/或主辦機構規定須投保的其他風險(包括但不僅限於使用保險庫或貯物室)，投購有效及充分的保險。此外，參展商必須遵從包括但不限於香港條例第 282 章僱員補償條例(“該條例”)第 40 條的規定，以承擔該參展商在該條例及普通法就他們全部的僱員在工作時受傷而引起的法律責任，不論僱員的合約期或工作時數長短、是全職或兼職、是長工或臨時工。對於參展商或任何其他人士就展覽(包括但不限於盜竊、使用保險庫或貯物室服務或展覽中心因任何原因出現缺陷)而蒙受或招致任何損失(包括相應損失)、損毀、索求、費用、申索、收費或任何種類的其他開支，主辦機構(包括其職員、董事、高級人員及代理人)一概不負任何責任。為防止任何損失或損毀，參展商可自費聘用保安護衛人員，在遷進及遷出期間內，護送展品進出展覽中心。
- 展館內嚴禁吸煙，每個特裝展台必須在易見處粘貼 200mmX200mm 正方形禁煙標識，100 m²以下不能少於 2 處，100 m²至 300 m²不能少於 4 處，300 m²以上不能少於 6 處，二層結構的展台在此基礎上增加 50%。
- 展館內嚴禁使用易燃(彈力布、稻草等)、易爆物品以及含有輻射、放射、有毒、腐蝕性高揮發物品等。
- 為安全起見，於展會期間參展商應妥善安排所有包裝物料，例如紙箱、木箱、塑膠包裝材料等，不可存放於展位橫樑上或靠近電力裝置、射燈及燈飾展品的地方，及隨意棄置於展位外。如因此舉構成之危險，引致火災及展位倒塌，主辦機構將保留追究之權利。一經發現違規處置之包裝物料，主辦機構將代為處理，不予發還，並不作另行通知，主辦機構一概不會就包裝物料之遺失或損毀負責。請參展商妥善處置所有包裝物料，參展商有責任自行與貨運安排代為存放，或儲存於展位內。
- 展館內嚴禁私拉、亂接電源綫；照明燈具、霓虹燈、各種用電設施及材料應具有國家專業安全認證，應按照國家電氣規程標準施工、安裝和使用。嚴禁使用麻花電綫連接電器設備，應當使用標準的雙護套阻燃電綫連接電器設備，展位電路、電器必須採用接綫端子連接。電路、電器的安裝必須由持有有效操作證件的人員進行施工，展會期間電工必須隨身攜帶操作證件，以備核查。
- 請參展商選擇環保和阻燃材料進行展位裝修，不得使用可燃或易燃材料進行搭建裝修。電源接頭應採用脫離後無觸點外露的插拔組件連接，如採用端子連接，端子必須完全封閉，不得外露(可採用阻燃絕緣明裝盒封閉)。所有電源綫均應使用雙層絕緣護套銅綫，絕緣強度須符合標準。根據用電量選配導綫截面積，連接燈具的絕緣導綫最小截面積為 1mm²。易燃材料背面必須刷防火塗料。展位燈箱製作，必須採用防火塗料進行防火處理；燈箱內燈具安裝必須要與燈箱主體有一定距離空間；燈箱製作完畢必須預留散熱空。
- 特裝展位必須配備合格、有效的乾粉滅火器具(2 公斤起)，滅火器在展位入場施工時必須均勻擺放在展位區域四周明顯、易操作的位置，便於消防檢查和使用，滅火器配備標準為 50 m²內 4 具，50 m²外每增加 50 m²增加 2 具(不足 50 m²按 50 m²計算)，以此類推。搭建二層建築的展位，滅火器配置標準在此基礎上增加 50%。為保障展會安全，必須統一使用場館提供的滅火器材。
- 所有特裝展位，安裝吊頂裝飾，不得超過展位總面積三分之一，採用紡織品吊頂，在安裝過程中必須與燈具保持 50 公分以上距離，並要對採用的紡織品做防火處理。
- 佈展施工必須在自有展位範圍內進行，不得超範圍跨區佈展，施工材料、工具應規範、平整放置在本展位範圍內，不得豎立、堆碼在展位中市和消防通道，如阻塞通道，展館將視其為廢棄物料處理。
- 嚴禁利用展館頂部網架作為吊裝展位結構的工具，嚴禁在防火捲簾門下搭建展位及堆放物品，嚴禁遮擋展館消防設施設備(消防栓、紅外對射、監控探頭、消防通道等)。內嚴禁吸煙，嚴禁使用明火。
- 展館內禁止電、氣焊(氣體瓶嚴禁入館)等明火作業。如必須使用的單位，需提前向場館施工管理辦公室書面申請、安全承諾書並附上操作人員的相關證件，申請通過後，在繳納相關動火費用(300 元/1 處/1 天)並採取有效的防範措施、配置相應數量的滅火器後方可使用。違者將按相關規定嚴肅處理。

PART VII 第七部份 Remarks for Custom-Built Exhibitor 特裝參展參展商須知

- Custom-built booth management fee and administration fee of contractor's badges may be charged by the venue owner. And the aforesaid fee will be at exhibitor's cost.
展會場館(即福州香格里拉大酒店)將有機會向參展商收取特裝管理費及施工証行政費。
- For Custom-Built Participation Exhibitors, Contractors' Information, construction drawings and lighting distribution plan, etc., should be submitted to the Venue Owner and the Organiser for approval before the fair commences. Drawings submitted must be in reasonable scale, fully dimensioned and must contain information such as floor plan, stand elevation, electrical fittings, carpeting, colours and materials to be used, moving exhibits, audio-visual equipment, weights and point loading of exhibits etc. Any alterations after drawing submission should be addressed to the Venue Owner and the Organiser for review. For details, please refer to the Exhibitor Manual and Notice for Custom-Built Participation Exhibitor.
參展商需於佈展前(有關截止日期及詳情請留意參展商手冊及特裝參展商須知)向展覽場館提供攤位設計圖紙、使用材料和用電負荷等相關資料，並經展覽場館批准後憑場館所頒發的施工證件方可進館施工。

PART VIII 第八部份 Enrolment Information 報名須知

Have you Included? 你是否已提供：

- Completed application form with Signature in Part IX 填妥之參加表格並於第九部份簽署
- Copy of Business Registration Certificate 商業登記証副本
- Participation fee 參加費用 (只包括
- CD-ROM with your Company Profile in Chinese and Project Photo 附有 貴公司中文公司簡介及作品照片的光碟

Please return all application material to our office **on/before 31 March 2017 (Friday).**

請將所有參展資料於截止日期 **2017年3月31日(星期五)或以前**交回本局。

Mailing Address 郵寄地址： Hong Kong Trade Development Council (Service Promotion Department),
38/F, Office Tower, Convention Plaza, 1 Harbour Road, Wanchai, Hong Kong (Attention: Ms. Gloria Ng / Ms Jeani Wang)
香港貿易發展局服務業拓展部 香港灣仔港灣道1號會展廣場辦公大樓38樓 (收件人：Ms. Gloria Ng / Ms Jeani Wang)

Enquiry 查詢：	Tel 電話	E-mail 電郵
Miss Gloria Ng 吳小姐	2584 4510	gloria.tk.ng@hktdc.org
Miss Jeani Wang 王小姐	2584 4532	jeani.wz.wang@hktdc.org

PART IX 第九部份 Terms & Conditions 條款

We (Name of Company) 本公司(公司名稱) _____

hereby apply for joining SmartHK in Fuzhou. We agree to abide by the "Conditions of Participation" set out by the Organiser. We understand that the above information will be included into HKTDC's databank for trade promotion purposes and for any other purposes as stated in the HKTDC's Private Policy Statement. And the Organiser can make use of the above information and may on-pass to third parties for promotion of SmartHK. We accept that the Organiser bears no responsibility for any error or omission.

茲申請參加於福州舉辦的「SmartHK 創新升級·香港論壇」，並同意遵守主辦機構訂定的參展細則。本公司明白上述資料將會儲存在香港貿易發展局資料庫內，供主辦機構作貿易拓展之用，以及用於香港貿易發展局在私隱政策聲明中所述之其他用途，同時亦可轉交其他機構，作為推廣「SmartHK 創新升級·香港論壇」之用。本公司同意，上述資料如有錯漏，主辦機構毋須負責。

- If you do not wish to have your information on-passed to third parties for promotion of the SmartHK, please ✓ against the box.
倘若 貴公司不欲將有關資料轉交至其他機構作為推廣「SmartHK 創新升級·香港論壇」之用，請於方格內加上✓號。
- Please tick here if you object to our use of your data for direct marketing. 若閣下反對我們將閣下的資料用於進行直接促銷，請於方格內加上✓號。
(If in the future, you no longer wish to receive any promotional and other materials from the HKTDC, please contact our Customer Service Hotline at (852) 1830668 or hktdc@hktdc.org. We will not send you any promotional and other materials upon receiving your request with no charge 若閣下不欲收取香港貿易發展局的任何宣傳及其他資料，請聯絡本局客戶服務部 (852) 1830668 或 hktdc@hktdc.org。我們在收到閣下要求後，在不收費用的情況下停止寄給閣下任何宣傳及其他資料。)

We warrant that any materials provided to the Organiser do not in any way whatever violate or infringe any third party's rights including all intellectual property rights including but not limited to trade marks, copyright, designs, names, and patents whether registered or otherwise. We agree to fully indemnify the Organiser and its agents, representatives, contractors and employees against all costs, expenses and damages arising from any third party's claim of infringements by us and/or the Organiser and/or the latter's agents, representatives, contractors or employees of such third party's rights. 本公司保證提交予主辦機構的任何資料，各方面均沒有違反或侵犯任何第三者的權利，包括所有知識產權，其中包括但不限於已註冊或未註冊的商標、版權、外觀設計、名稱及專利；並同意悉數賠償主辦機構及其代理、代表、承包商和僱員因第三者指控本公司及/或主辦機構及/或後者的代理、代表、承包商和僱員侵權而招致的費用，開支及索償。

We accept that the Organiser bears no responsibility for any error or omission.

本公司同意，上述資料如有錯漏，主辦機構毋須負責。

We understand that participation fee is non-refundable once the participation has been accepted.

本公司明白參加申請一經確定接納，參加費概不獲發還。

Name of Person-in-charge Signature: 負責人姓名：	Position: 職位：
_____	_____
Company Stamp & Authorised Signature: 公司印鑑及負責人簽署：	Date: 日期：
_____	_____

CONDITIONS OF PARTICIPATION

1. DEFINITIONS

In these Conditions of Participation and the Application Form, save as the context otherwise requires:

"Applicant" means the company named in Part I of the Application Form.

"Application" means the application by the Applicant to participate in the Exhibition, made by submitting the Application Form together with all necessary payments to the Council.

"Application Form" means the application form to which these conditions are annexed.

"Booth" means a booth in the Exhibition which the Council licenses the Participant to use for the duration of the Exhibition.

"Conditions" means these Conditions of Participation as amended by the Council from time to time.

"Council" means the Hong Kong Trade Development Council.

"Delegate(s)" means the individual(s) named in Part I of the Application Form who is/are nominated by the Participant to attend and represent it at the Exhibition.

"Executive Director" means the Executive Director appointed by the Council from time to time;

"Exhibition" means the event, fair or exhibition named in the Application Form.

"Hong Kong" means the Hong Kong Special Administrative Region of the People's Republic of China.

"Optional Participation Expenses" means the amount payable by each Participant for additional facilities and services such as shipment of samples, accommodations, travel expenses, extra stand facilities and interpreters, provided by the Council at its request, which amount shall be determined by the Council.

"Participant" means the Applicant after its Application has been accepted by the Council.

"Participation Fee" means the amount payable by the Participant to the Council for the right to participate in the Exhibition, as specified in Part V of the Application Form.

"Products" means the goods and services described in Part I & III of the Application Form and which the Council agrees to accept for exhibiting at the Booth during the Exhibition.

"Project Manager" means the project manager for the Exhibition appointed by the Council.

"Publicity Material" means all and any promotional gifts, catalogues, pamphlets, advertising and publicity material whatsoever which the Participant wishes to display, distribute or use at or for the purpose of the Exhibition.

"Related Companies" in respect of the Applicant or Participant means its holding companies, subsidiaries and subsidiaries of its holding companies.

2. ACCEPTANCE

(a) The Applicant must be a Hong Kong entity with a valid Hong Kong business registration certificate with substantial operations in Hong Kong.

(b) The Executive Director, on behalf of the Council, may in his absolute discretion accept or reject the Application without providing any reasons therefore.

(c) The Applicant represents and warrants that none of its Related Companies, associates, or persons or companies that are effectively under its control has applied to participate in the Exhibition. The Council has an absolute discretion to reject the Application or withdraw its acceptance of the Application if the Applicant shall have breached this warranty and representation.

3. PAYMENT

(a) Upon submission of its Application, the Applicant shall pay to the Council such amounts and in such manner as set out in Part V of the Application Form.

(b) If the Applicant has requested for additional facilities and services in accordance with Part V of the Application Form, it shall further pay to the Council upon submission of its written request for such services and facilities:

i. such amount as the Council in its sole discretion considers appropriate as deposit for the Optional Participation Expenses if such request is made prior to the commencement of the Exhibition; and

ii. the full amount of the Optional Participation Expenses if such request is made on-the-spot during the Exhibition (see paragraph 3(e) below).

(c) If the Application is rejected, the Council will within 30 days of the date of notice of rejection refund to the Applicant all amounts received by it from the Applicant pursuant to paragraphs 3(a) and 3(b) above without interest.

(d) When the Application is accepted by the Council, the Applicant will become a Participant. If it subsequently wishes to withdraw its participation, it may do so by notice in writing to the Council whereupon the Participation Fee will be forfeited by the Council. All Optional Participation Expenses paid by the Participant for the optional and additional facilities and services will be refunded to the Participant within 30 days of the date of notice of withdrawal of its participation provided these expenses have not been incurred by or on behalf of the Participant.

(e) The Participant may request for additional facilities and services on-the-spot during the Exhibition but all fees in relation to such request must be paid in full by the Delegates before the additional facilities and services are provided by the Council or its contractor. All such requests must be made in writing to the Council directly.

(f) i. If the Participant requests the Council or its recommended travel agent (the "Agent") to reserve hotel accommodation for its Delegates, the Participant shall pay to the Council or the Agent such amount as the Council or the Agent may deem appropriate as deposit which shall be at least equal to the first night's accommodation charges at the hotel. The Council or the Agent will endeavour to reserve accommodation in its name for the Delegates and on reserving the accommodation, pay to the hotel the amount which it has received from the Participant.

ii. The Delegates shall settle with the hotel directly the balance in full of all charges incurred by them at the hotel when they check out from the hotel.

iii. The Participant shall indemnify the Council against all liabilities incurred by its Delegates in connection with the hotel and shall on demand pay to the Council immediately all amounts claimed by the hotel against the Council in respect thereof.

(g) i. In no case will action be taken by the Council until and unless the respective amounts payable pursuant to this paragraph 3 and Part V of the Application Form have been paid in full to the Council.

ii. If the Council requests any additional amount to be paid by the Applicant/Participant, no further action will be taken by the Council until and unless such additional amount has been paid in full to it.

(h) All payments by the Participant to the Council shall be made promptly without any deduction, set-off or counterclaim.

(i) All requests by the Participant for any additional facilities and services are subject to the Council's ability to procure such facilities and services. The Council does not warrant or represent that it will be able to procure any such facilities or services. If the Council is unable to procure the requested facilities or services, it will as soon as practicable inform the Participant and will refund to the Participant any amount received by it in relation to such requested facilities or services.

(j) The Council accepts no liabilities and gives no warranties or representations in respect of the quality, standard, fitness for any purpose, timing of the provision or otherwise of any of the facilities or services provided by the Council at the Participant's request.

(k) The Council shall have discretion to deduct from the deposit paid for Optional Participation Expenses under paragraph 3(b) against any losses or expenses incurred by it by reason of the failure of the Participant to comply with the Conditions or supplying false or misleading information to the Council.

(l) The Participant shall reimburse the Council of all Optional Participation Expenses paid on its behalf. If, in the opinion of the Council, the deposit paid for Optional Participation Expenses under paragraph 3(b) is or will

likely be insufficient to pay for all the actual expenses to be incurred by the Council, the Council may at any time request an additional amount to be paid by the Participant which, in the opinion of the Council, is sufficient to pay for such actual expenses. The Participant shall, within 5 days of receiving such request, pay the requested amount to the Council. No further action will be taken by the Council until and unless such additional amount has been paid in full.

4. SETTLEMENT OF ACCOUNTS

(a) The Council will issue a statement of account to the Participant setting out the actual cost of the provision of any additional facilities and services, the amount of deposit paid for Optional Participation Expenses and the balance due to the Council (where the actual cost exceeds the deposit) or the amount of refund to the Participant (where the actual cost is less than the deposit).

(b) The Participant shall pay to the Council the amount due to the Council as shown on the statement of account within 14 days of its receipt. A surcharge of 2% per month will be imposed on any outstanding amounts after the due date for payment.

(c) The Council will refund the amount to be refunded to the Participant as shown on the statement of account on delivering the statement of account to the Participant.

(d) The Council reserves the right to offset any balance to be refunded to the Applicant/Participant against any outstanding liabilities due by the latter to the Council in relation to their participation in the Council's other activities.

(e) No interest will be payable by the Council in respect of any refund amounts to the Applicant/Participant.

5. BOOTH

(a) The Council will in its absolute discretion allocate 1 Booth to the Participant by way of a licence for the exhibition of its Products. The Participant shall have no claims whatsoever against the Council in respect of any loss or damage suffered by the Participant and/or its officers, representatives, agents and employees (including without limitation any loss or damage arising from any liability incurred to third party) whatsoever caused by the location, construction or material of the Booth allocated to it unless such loss or damage involves death or personal injury resulting from the negligence of the Council.

(b) The Participant shall not assign its licence to occupy the Booth or part with the possession of or permit any third party to occupy the Booth or any part thereof regardless of the relationship between the third party and the Participant.

(c) In the interests of maintaining a high standard of presentation at the Exhibition and a favourable image of Hong Kong as a whole, the Project Manager may in his absolute discretion require the Participant to withdraw or alter in any way the presentation of any Products or Publicity Material.

(d) No alteration or addition to the Booth or its fittings may be made by or on behalf of the Participant without the prior permission of the Project Manager.

(e) The Participant must not obstruct or cause to be obstructed any entrances to or passage to or passage ways in the Exhibition.

6. PARTICIPATION IN THE EXHIBITION

(a) The Participant must be represented at the Exhibition by at least 1 Delegate.

(b) Any Delegate nominated to represent the Participant at the Exhibition must be a senior executive of the Participant.

(c) The Participant shall ensure that:-

i. at least one Delegate shall be in attendance at its Booth at all times when the Exhibition is open to visitors;

ii. each of its Delegates shall be fully conversant with the Products and shall be duly authorised to negotiate and conclude contracts for the sale of the Products;

iii. its Delegates shall comply with the Conditions and with all directions which the Project Manager may from time to time give in connection with any matter appertaining to the Exhibition.

(d) The Council reserves the right in its absolute discretion and without giving any reasons to require the Participant to replace any of its Delegates forthwith.

(e) The Participant shall use its best endeavours to uphold the reputation of the Council and to promote the success of the Exhibition.

(f) The Participant shall abide by the regulations contained in the official application form submitted to the organisers of the Exhibition by the Council on behalf of the Participant. Such regulations are deemed to be an integral part of the Conditions.

7. PRODUCTS

(a) The Council shall have an absolute discretion to accept or reject any of the Participant's products for exhibiting in the Exhibition without providing any reasons therefore.

(b) The Participant may only exhibit Products which are produced by Hong Kong entities.

(c) The Participant warrants that (i) the Products and the packaging, and (ii) all information, statements, photographs and illustration provided for publication of mission catalogue and/or other publicity materials thereof do not in any way whatsoever violate any third party rights including without limitation trade marks, copyrights, designs, names and patents whether registered or otherwise.

(d) The Participant undertakes not to display anything which is unlawful, in breach of any person's intellectual property, harmful, threatening, violent, offensive, defamatory, libelous, scandalous, seditious, vulgar, obscene, indecent, invasive of another's privacy, hateful, racially, ethnically or otherwise objectionable.

(e) The Participant warrants that (i) the Products and the packaging, and (ii) all information, statements, photographs and illustration provided for publication of mission catalogue and/or other publicity materials thereof do not in any way whatsoever violate any applicable laws, rules and regulations of the importing countries.

(f) The Participant shall be solely responsible for and shall settle all expenses and liabilities incurred by it in relation to its participation in the Exhibition including without limitation all shipping and transportation charges, customs duties, handling charges and other costs and expenses arising from the shipment or any other mode of transportation of the Products in connection with the Exhibition. If the Council pays any of such charges, duties, costs or expenses on behalf of the Participant it shall be entitled to reimbursement from the Participant on demand and may offset any amount held by it on behalf of the Participant against such payment.

8. BUSINESS PRACTICES

(a) The Participant warrants and agrees that it will conduct itself and carry out its business in the Exhibition according to the ethical business practices. The Council may provide the guidelines regarding such ethical business practices to be observed by the Participant from time to time.

(b) The Participant agrees that it will immediately withdraw any products or publicity materials, or stop promoting any products or services in any particular manner, which in the absolute discretion of the Project Manager, is inconsistent with ethical business practices, or may affect the image of Hong Kong or the Exhibition, upon notice of the Project Manager.

(c) The Participant agrees that it will be responsible for the repair, replacement or full refund of any products sold at the Exhibition if the product is returned to the Participant within 30 days from the date of sale. Any such request for repair, replacement or refund shall be processed expeditiously by the Participant, and in any event not longer than 30 days from the date of return.

9. PUBLICITY

The Council will arrange for such publicity for the Exhibition as it shall in its absolute discretion deem fit. No Participant, Delegate or other officer, representative, agent or employee of the Participant shall give or cause to be

given any interview, public announcement, press statement or any other publicity whatsoever in relation to the Exhibition.

10. INFORMATION

(a) During the Exhibition the Delegate shall provide the Council with such information as to the business results of the Participant in the Exhibition as the Project Manager may from time to time request. Such information will not be divulged to third parties without the Participant's approval, save in relation to collective figures in respect of all or a majority of the persons or companies participating in the Exhibition.

(b) At the conclusion of the Exhibition the Delegates shall complete questionnaires on the activities performed and the business carried out by the Participant during the Exhibition for the information of and further action by the Council.

11. TERMINATION OF RIGHT TO PARTICIPATE

(a) Without prejudice to the Council's other rights and remedies, the Council has the right to terminate forthwith by notice the Participant's right to participate in the Exhibition on or following the occurrence of any of the following events:-

i. if the Participant or any of its Delegates, officers, representatives, agents or employees commits a breach of any of the Conditions;

ii. if the Participant, being a body corporate, enters into liquidation whether compulsorily or voluntarily or compounds with its creditors or has a receiver appointed over all or any part of its assets or if the Participant, being a sole proprietorship or partnership, becomes or one of its members becomes bankrupt or insolvent or enters into any arrangements with its creditors;

iii. if the Executive Director in his absolute discretion decides that such right shall be terminated;

(b) The Participant's right to participate in the Exhibition shall automatically terminate in the event that all its Delegates are refused entry visa or entry permit to the country or place where the Exhibition shall be held by any competent authorities.

(c) In the event that the Participant's right to participate in the Exhibition is terminated, any expenses incurred by the Council for and on behalf of the Participant prior to such termination and all other expenses reasonably incurred by the Council as a consequence of such termination shall be paid on demand by the Participant to the Council.

(d) The Council reserves the right to terminate the Exhibitor's right to participate in any future Exhibition if the Exhibitor is found to have committed any act including but not limited to failing to respect intellectual property rights of any other party, non-compliance with product safety, environmental laws and/or any other act which, in the sole opinion of the Organiser of the Exhibition and the Council, might damage the reputation and/or image of Hong Kong, its industries, the fair, the Organiser of the Exhibition and/or the Council or if the Executive Director in his absolute discretion decides that such right shall be terminated.

12. CANCELLATION

The Council reserves the right to cancel the Exhibition at any time without incurring any liability whatsoever to the Participant and its Delegates if circumstances outside the reasonable control of the Council (including but not limited to war, embargo, civil unrest, terrorist attacks, legal proceedings or government regulations) make it in the sole opinion of the Council (which opinion shall be conclusive) impossible, impractical or undesirable for the Council to participate in or hold the Exhibition.

13. EXCLUSION OF LIABILITY

(a) The Council shall not be liable for any loss, damage or personal injury howsoever suffered by or caused to the Participant or its Delegates, officers, representatives, agents, employees or any third party, or its Products or other property in the course of or in relation to the Exhibition, unless such loss, damage or personal injury shall be caused by any breach by the Council or its employees of the Conditions.

(b) The Council assumes no responsibilities for any introduction or transaction made between the Participant and any third party during or as a result of the Exhibition.

(c) The Participant shall be responsible for effecting all insurance coverage necessary in connection with its participation in the Exhibition including but not limited to insurance in respect of the Products, its other property and its Delegates (including travel and medical insurance).

(d) The Participant undertakes to indemnify and at all times hereafter to keep indemnified the Council from and against all liabilities, actions, proceedings, claims, damages, costs and expenses whatsoever which it may suffer or incur by reason of or in relation to any act, omission or default by the Participant or its Delegates, officers, representatives, agents and employees in the course of or in relation to the Exhibition.

14. CONFIDENTIAL INFORMATION

The Participant shall not disclose or permit to be disclosed to any person or otherwise make use of or permit to be made use of any information relating to the business or affairs of the Council or other participants in the Exhibition which has been acquired by reason of the Participant's participation in the Exhibition.

15. WAIVER

No failure or delay by the Council in exercising or enforcing any right or power hereunder shall operate or be construed or operated as a waiver thereof. No waiver of any breach shall be construed as a waiver of any continuing or subsequent breach.

16. NOTICE

(a) Every notice or demand shall be in writing but may be given or made by post, cable, telex or fax.

(b) Every notice or demand to be given by the Council may be sent to the address of the Participant stated in its Application Form. Every notice to be given by the Participant to the Council shall be sent to the offices of the Council at 38th Floor, Office Tower, Convention Plaza, 1 Harbour Road, Hong Kong.

(c) Every notice or demand shall be deemed to have been received in the case of a telex, or fax, at the time of despatch, and in the case of a letter three days after the posting of the same by prepaid post.

17. GENERAL

(a) Nothing in the Application Form or the Conditions shall create or be deemed to create a partnership or the relationship of principal and agent or employer and employee between the Council and the Participant.

(b) The Application Form and the Conditions embody and set out the entire agreement and understanding of the parties and supersede all prior oral or written agreements, understandings or arrangements between the Council and the Applicant relating to the Exhibition.

(c) The Council reserves the right to alter and amend any of these Conditions and to issue additional rules and regulations (including but not limited to the participants' manual) at any time it considers necessary for the orderly operation of the Exhibition. The amended Conditions and the additional rules and regulations shall be sent to the Participant and become effective immediately. The Participant will be deemed to have notice of the same and have accepted the amended Conditions and the additional rules and regulations. The Participant acknowledges that the Council shall have the right to interpret these Conditions, additional rules and regulations together any amendments thereof. All interpretations of these Conditions, any additional rules and regulations, and any amendments thereof by the Council shall be final and binding on the Participants.

18. GOVERNING LAW

The Application Form and the Conditions shall be governed by and construed in all respects in accordance with the laws of Hong Kong and all the parties agree to submit to the non-exclusive jurisdiction of the Hong Kong court.